

Operating instructions

english
for

MPI-Modem

Version 1.2

© Copyright 2006 by PI

Contents

1 MPI-MODEM.....	3
1.1 Functional Description	3
1.2 MPI-MODEM as TS-Adapter	3
1.3 Pin assignment	4
1.3.1 Pinning RS232 (PC-side)	4
1.3.2 Pinning MPI (PLC-side)	6
1.3.3 External Power-Connector	7
1.3.4 Light emitting Diodes	8
1.3.5 analogue Phone-Connector	9
1.4 Connecting the MPI-Modem	10
1.5 Display and Keyboard of the MPI-MODEM Cable	11
1.5.1 The Keyboard	15
1.5.2 Main Menu	16
1.5.3 Info	16
1.5.3.1 Version	17
1.5.3.2 Signalquality	17
1.5.3.3 Signallevel	17
1.5.4 Bus	18
1.5.4.1 Adressen	18
1.5.5 Config	19
1.5.5.1 PG/PC	19
1.5.5.2 MPI Accs	20
1.5.5.2.1 Serial	20
1.5.5.2.2 MODEM	21
1.5.5.3 PPI-Accs	21
1.5.5.3.1 Serial	21
1.5.5.3.2 MODEM	22
1.5.5.4 Modem	22
1.5.5.4.1 Dial mode	23
1.5.5.4.2 phonebook	23
1.5.5.4.3 Baudrate	24
1.5.5.4.4 Modemtype	24
1.5.5.4.5 Speaker	24
1.5.5.4.6 busy identification	25
1.5.5.4.7 ring counter	25
1.5.5.4.8 extension	26
1.5.5.4.9 outline code	26
1.5.5.5 MPI-BUS	26

1.5.5.5.1 Baudrate	27
1.5.5.5.2 HSA.....	27
1.5.5.5.3 local Nr.....	28
1.5.5.6 Language	28
1.5.5.7 Erase.....	28
1.5.6 Hang up.....	29
1.5.7 Call	29
1.6 Technical data	30

1 MPI-MODEM

1.1 Functional Description

The MPI-Modem connects the programming device or PC over the serial Interface (COM-Port) or by Modem to the PC over an analog telephone line with the MPI- or DP/FMS-Connector of the S7-300/400 PLC. The MPI-Modem selects automatically on the first access which Port and which Baud rate is used. With our PLC-Programming-Application PG-95/PG-2000 or S7-for-Windows works the MPI-Modem with up to 115.2kBaud on the PC - Side.

On the MPI-Side you could use Baud rates from 19k2 up to 12MBaud.

It is possible use the MPI-Modem on a MPI-Connection with only the 2 Data-Lines.

1.2 MPI-MODEM as TS-Adapter

The TS-possibility allows the connection of a modem, to make a connection with a 2nd Modem and a PC to a S7-300/400. The MPI-Modem must be connected to an analoge telephone line and the PLC .

To work with the MPI-Modem in his TS-function, you must make the following actions:

Handbook Cable & Adapter

- 1) You need the TeleService-software from Siemens in your PC to work with the MPI-Modem. The configuration of the MPI-Modem can be made with the TeleService-software from Siemens or with the “MPI-Kabel Manager”.
- 2) On the PC side you need another modem.

1.3 Pin assignment

1.3.1 Pinning RS232 (PC-side)

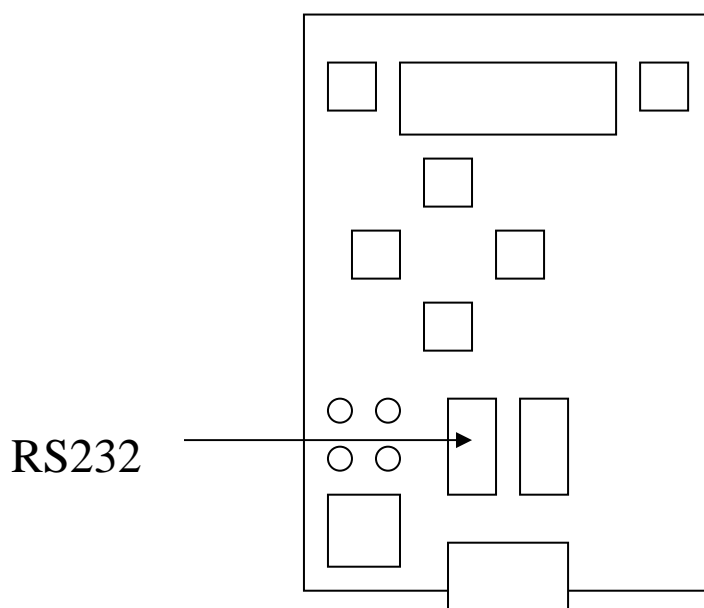

Pin No.	Notation	Description	Direction (of cable)
1	DCD	Data Carrier Detect	Out
2	TXD	Transmitted Data	Out
3	RXD	Received Data	In
4	DSR	Data Set Ready	In
5	GND	Signal Ground	
6	DTR	Data Terminal Ready	Out
7	CTS	Clear to Send	In
8	RTS	Request to Send	Out
9	RI	Ring Indicator	In
Shield		On connector casing	

The shield is connected with the RS232 connector via the shield of the adapter casing. This MPI-Modem is designed to be connected directly on a COM interface of a PC. The cable can be lengthened by a 1:1-cable to the PC up to 15m maximum. The cable should have a good quality and the shield should be connected at both sides at the SUB-D case.

1.3.2 Pinning MPI (PLC-side)

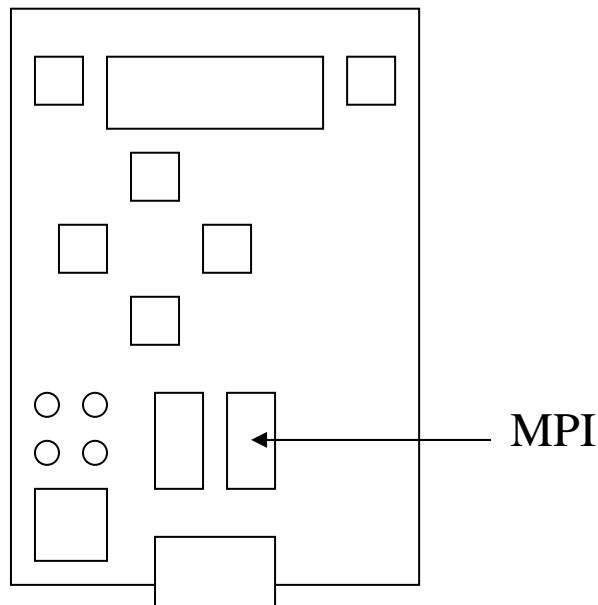

Pin No.	Notation	Description	Direction (of cable)
1	NC	Not Connected	
2	NC	Not Connected	
3	Ltg_B	Data line B	BiDir.
4	RTS-AS	Request to Send from the PLC	In
5	M5V	Ground of the 5V	In
6	P5V	5V output	Out
7	NC	Not Connected	
8	Ltg_A	Data line A	BiDir.
9	RTS-PG	Request to Send to the PLC	Out
Shield		On connector casing	

The shield is attached with the MPI connector via the shield of the adapter casing. To find directly attended PLC's, RTS-AS and M5V must be connected in the cable. P5V means a output of the cable and works only as an output for a bus-termination with resistors. This 5V output doesn't drive any load and have a 100R resistor inside his direction.

Attention:

Don't lengthen the connection by a 1:1 cable to the PLC, because there are 24V and 5V inside of the cable. The quality of the bus-signal will be risen down!

To lengthen the connection, please use a MPI-NETZ-Adapter and connect only the signals Ltg_A and Ltg_B 1:1 and the shield at both sides of the metal-casing at the SUB-D connector

1.3.3 External Power-Connector

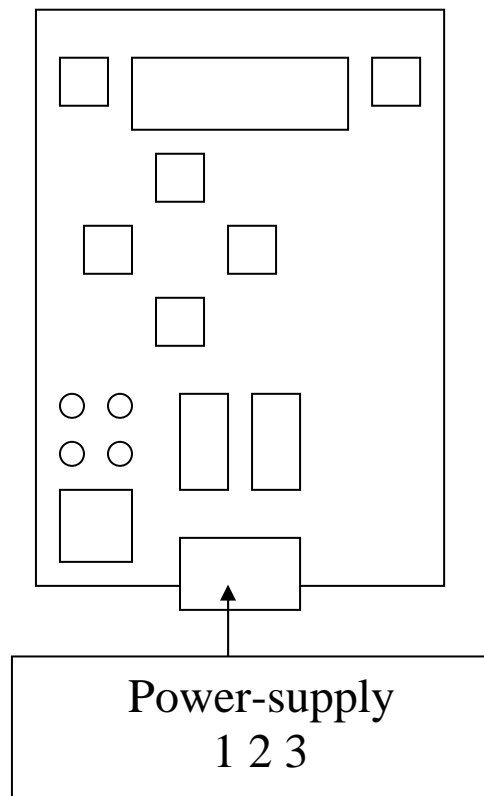

Pin No.	Notation	Description	In/Out (of Cable)
1	P24V	24V Power	In
2	GND	Ground	In
3	M24V	Ground 24V	In

You need a power-supply +24VDC +/- 20%, 5VA. The protective ground could also be connected to a cable-shoe on the bottom of the powder-coated metal-case. The Powder-

Handbook Cable & Adapter

coated case is isolating, mounting to the back-plane does **not** connect to protective ground !

1.3.4 Light emitting Diodes

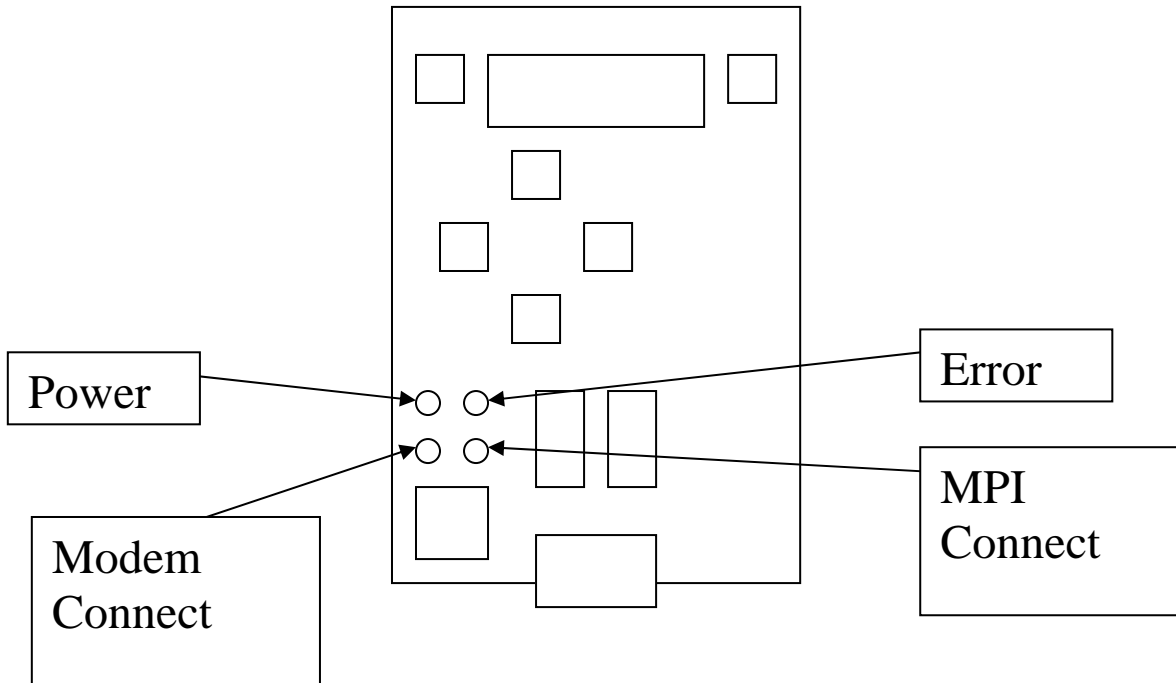

LED	Color	Position
Power	Green	upper left
Error	Red	upper right
Phone connection established	Yellow	lower left
MPI-Connection	Yellow	lower right

1.3.5 analogue Phone-Connector

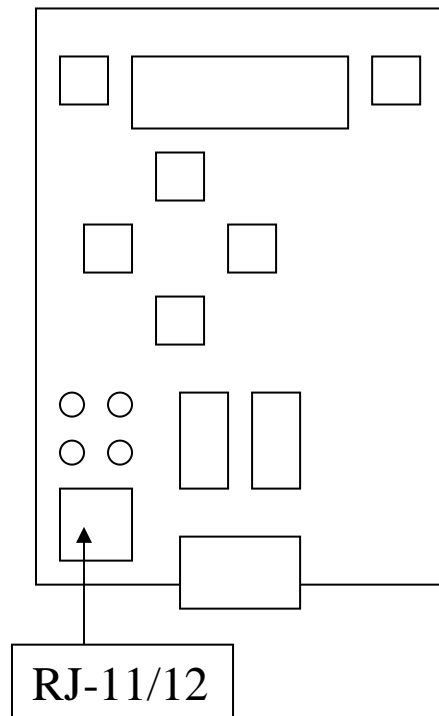

Pin No	Notation	Description	In/Out (of cable)
1	NC	Not connected	
2	A'	Pass-through line A	Out
3	A	Line A	In
4	B	Line B	In
5	B'	Pass-through line B	Out
6	NC	Not connected	

Analogue female Phone-Connector RJ-11/12, in China use the DDE-Net (recommended).

1.4 Connecting the MPI-Modem

This MPI-Modem will be connected with the right connector to the MPI- or the DP/FMS-Interface of the PLC. The MPI-Modem is power supplied with an external 24V voltage.

The left connector could be connected to the programming-device or with an PC to the COM-Port.

When the MPI-Modem gets the power it shows the software-version in the display and begins with the test of its internal components. On the display all relevant data is displayed.

The cable will find at a MPI-Connection the active baud rate to the programming-device or to the PC in the first time of communication and set his baud rate himself.

If you want to connect the cable to the 25-pin connector of the PC, you can use an adapter (9 pin to 25 pin sub miniature D-connector) to work with this port.

In the PC-Software you must adjust some parameters like the baud rate (19,2 or 38,4 kbaud) and the connected COM-PORT (COM1 or COM2) and the used adapter as 'TS-Adapter'.

1.5 Display and Keyboard of the MPI-MODEM Cable

After Reset the Display shows all relevant Data of the PLC-Connection.

Example for Display:

```
#02TD00 ■ | MODEM BE
!02AG04 |
```

In the first line there are displayed from left to right the following Information:

1.) A Sharp „#“ with the number of connected active stations on the MPI-Bus (in this example 2)

2.) The PC-Baud rate

MD	115,2k or automatic Baudrate-Selection active (Modem)
TD	115,2k or automatic Baudrate-Selection active (serial line)
MS	19,2k (Modem)
TS	19,2k (serial line)
Ms	38,4k (Modem)
Ts	38,4k (serial line)
mS	57,6k (Modem)
tS	57,6k (serial line)

3.) The station-number of MPI – II Cable (In S7-Manager under „Extras / PG/PC-Interface“ with “Properties/Net/locale station number“). The default is 0.

4.) When communicating a tiled bar (top is to PLC, bottom to PG)

In the second line there are display from left to right the following information:

- 1.) The first Char defines which type of PLC and which connection is used

!	Active Station in MPI-Bus, directly connected
?	Active Station in MPI-Bus, far distance
!	Passive Station in MPI-Bus, directly connected
?	Passive Station in MPI-Bus, far distance

2.) The station-numbers of all active and connected stations in the MPI-Bus. Every $\frac{3}{4}$ second another station is displayed.

3.) static Text „AG“ (means PLC)

4.) The PLC which is momentarily is connected to the PC-Software (in our example is the Station 4 connected).

On the right side of the display, separated by “|”, is the modem-state displayed.

In the first line the following messages could appear:

Message	Description
MODEM READY	The modem is booted and ready
MODEM ERROR	The modem reports an error
NO ANSWER	The modem don't send an answer
RING	The modem is called
CON.END	The connection is terminated
CONNECT <Bd>	The modem is connected to a line with the displayed Baudrate
NO CARRIER	The carrier is lost.
LINE BUSY	The phone-line or number is busy
BLACKLISTED	The called number is not allowed in the modem
NR.DELAYED	The number called is too often or fast redialed. The dialing is not allowed for a minute
FAX	Fax-call detected
DATA	Data-call detected
UNKNOWN MESS.	The modem generates an unknown message
DIALING	The phone-number which is dialed is shown in the bottom line
ENTRY EMPTY	The Fast-Access Entry is Empty
wrong PIN	The PIN-number configured is wrong
SIMCard wrong	The SIM-Card is not inserted, or not correctly placed.

Handbook Cable & Adapter

In the GSM-Version the display shows in the bottom line additional information about the GSM-Network:

Display	Description
SIM/PIN	SIM Card not inserted or PIN-Number wrong
RegDend	Registration denied in the GSM-network
Unknown	Unknown state
ROAM:<xx>	Connection established to a provider which is roaming. This could produce higher costs
GSM:<xx>	Connection established to a provider.
Srch:<xx>	Searching provider in GSM-network, not yet found

At „ROAM“, „GSM“ and „Srch“ additionally the Recieve-Quality is displayed (greater values are better).

--	no recieve (antenna not connected?)
01	very bad
31	best and optimal

1.5.1 The Keyboard

The keyboard on the back of the cable is used for navigating through menus and for configuring the cable. There are the following keys sensing and colored:

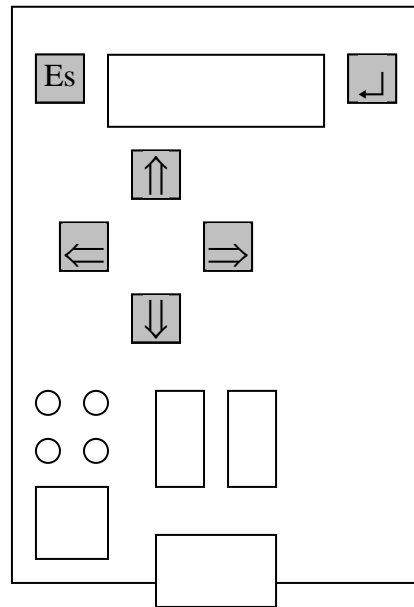

	Confirm the input, change into a menu or menu-point	ENTER
	Increasing a value, selecting a menu-point	UP
	Decreasing a value, selecting a menu-point	DOWN
	Cancellation of a input/selection, the selection is not saved, one menu-level back	LEFT
	Go into a sub-menu	RIGHT
	Go to state-message area	ESC

1.5.2 Main Menu

You select the main-menu with ENTER, with ENTER again you reactivate the default-display



With UP/DOWN you could choose the following menu-points:

Message	activate default-display
Info	Information over the MPI-MODEM cable
Bus	MPI-Bus information's
Config	Configuration of the cable
Hang up	tells the modem to hang up
Call	establishes a connection

1.5.3 Info

With RIGHT or ENTER you select the following sub-menu:

```
Info
Version
```

```
Info
Signal quality
```

```
Info
Signal level
```

1.5.3.1 *Version*

With RIGHT or ENTER you will enter the following display, which will display the actual operation system version of the cable:

```
Version  
1.01
```

With LEFT or ENTER you will leave this sub-menu-point to the menu info.

1.5.3.2 *Signalquality*

With RIGHT or ENTER you will enter the following display, which will display the actual signal quality of the connection:

```
Signalquality
```

With LEFT or ENTER you will leave this sub-menu-point to the menu info.

1.5.3.3 *Signallevel*

With RIGHT or ENTER you will enter the following display, which will display the actual signal quality of the connection:

```
Signallevel
```

With LEFT or ENTER you will leave this sub-menu-point to the menu info.

1.5.4 Bus

With RIGHT or ENTER you enter the following sub-menu which has only one element:

```
Bus  
Address
```

With LEFT you leave this sub-menu to the main-menu. With ENTER you enter the sub-menu.

1.5.4.1 Adressen

With RIGHT or ENTER you enter the following display, which shows the connected stations on the MPI-Bus:

```
Adressen  
D 018
```

With UP or DOWN you browse the addresses, where in the second line the following chars are possible:

D	The MPI-MODEM Cable is connected directly to this station
A	This station is active in the BUS
P	This station is passive like for example some OP's,FM or Profibus-Slaves.

With LEFT or ENTER you leave this sub-menu to the menu info.

1.5.5 Config

With RIGHT or ENTER a Password request is displayed. The Standard Password is "0". With ENTER you enter the following sub-menu where you could select the following sub-menus:

```
Config
PG/PC
```

With UP/DOWN you could choose the following sub-menus:

PG/PC	For selecting the function of the Cable.
Modem	configure the Modem
MPI-BUS	Configuration of the MPI-Parameter
Language	Selection of the Menu-Language
Set.Def	erases the Configuration, the Default-Properties are loaded
Password	Define a new Password

With LEFT you leave this sub-menu to the main-menu. With ENTER you enter the sub-menu.

1.5.5.1 PG/PC

With RIGHT or ENTER you enter the following sub-menu where you could select following menu-points::

```
PG/PC
MPI Accs
```

With UP/DOWN you select the following menu-points:

MPI Accs	The cable acts in a MPI-Bus
----------	-----------------------------

Handbook Cable & Adapter

PPI Accs The cable is connected to a S7-200

With LEFT you will leave this sub-menu to the menu mode.

1.5.5.2 MPI Accs

With RIGHT or ENTER you enter the following sub-menu where you could select following menu-points::

```
MPI Accs
Serial
```

With UP/DOWN you select the following menu-points:

Serial	Connect the PC over the serial line RS232
MODEM	Connect the PC over Telephone-line with the internal MODEM.

With LEFT you leave this sub-menu to the main-menu. With ENTER you enter the sub-menu.

1.5.5.2.1 Serial

With RIGHT or ENTER you enter the following sub-menu where you could select following menu-points::

```
Ser.Baud
19.2k
```

With UP/DOWN you select the following menu-points, with ENTER the selection is used:

19.2k	Baudrate 19200
38.4k	Baudrate 38400
57.6k	Baudrate 57600
115.2k	Baudrate 115200
Auto	The MPI-Modem selects automatically the baudrate

With LEFT (Cancel) or ENTER (Select) you will leave this Menu and go to PG/PC.

1.5.5.2.2 MODEM

With ENTER the Modem is the Accespoint.

1.5.5.3 *PPI-Accs*

With RIGHT or ENTER you enter the following sub-menu where you could select following menu-points::

```
MPI-Accs
Serial
```

With UP/DOWN you select the following menu-points:

Serial	Connect the PC over the serial line RS232
MODEM	Connect the PC over Telephone-line with the internal MODEM.

With LEFT you leave this sub-menu to the main-menu. With ENTER you enter the sub-menu.

1.5.5.3.1 Serial

With RIGHT or ENTER you enter the following sub-menu where you could select following menu-points::

```
Ser.Baud
9.6k
```

With UP/DOWN you select the following menu-points, with ENTER the selection is used:

9.6k	Baudrate 9600
19.2k	Baudrate 19200

Handbook Cable & Adapter

With LEFT you leave this sub-menu to the main-menu.

1.5.5.3.2 MODEM

With RIGHT or ENTER you enter the following sub-menu where you could select following menu-points::

```
ModmBaud
 9.6k
```

With UP/DOWN you select the following menu-points, with ENTER the selection is used:

```
9.6k      Baudrate 9600
19.2k     Baudrate 19200
```

With LEFT you leave this sub-menu to the main-menu.

1.5.5.4 Modem

With RIGHT or ENTER you enter the following sub-menu where you could select following menu-points::

```
Modem
dial mode
```

With UP/DOWN you select the following menu-points:

Dial mode	dial by tone or pulse
Phonebook	edit entries in the phonebook
Baudrate	Modem-baudrate over telephone line
Modemtype	select modemtype
Speaker	Speaker loudness
Busy identify	select busy identify
Ring counter	automatic connection
Extension	use extension
Outline code	if extension then define the outline code

With LEFT you leave this sub-menu to the main-menu. With ENTER you enter the sub-menu.

1.5.5.4.1 Dial mode

With RIGHT or ENTER you enter the following sub-menu where you could select following menu-points::

```
Dial mode
Tone
```

With UP/DOWN you select the following menu-points, with ENTER your selection is used:

tone	dialing with tones
pulse	dialing with pulses

1.5.5.4.2 phonebook

With RIGHT or ENTER you enter the following sub-menu where you can choose the phonebook entry to edit.

```
phonebook entry:
    1
```

Use UP und DOWN to select the phonebook entry. By pressing ENTER you can edit the entry.

```
phonebook entry:
> <
```

Handbook Cable & Adapter

With UP/DOWN/RIGHT/LEFT you can edit the phonebook entry. ENTER saves your changes, ESC will cancel the action.

1.5.5.4.3 Baudrate

With RIGHT or ENTER you enter the following sub-menu where you could select following menu-points::

```
Baudrate
 300 Bd
```

With UP/DOWN you select the following menu-points, with ENTER your selection is used:

300	1200	2400	4800	7200	9600
12000	14400	16800	19200	21600	24000
26400	28000	31200	33600		

automatic The Modem selects the appropriate baudrate by self.

1.5.5.4.4 Modemtype

With RIGHT or ENTER you enter the following sub-menu where you could select following menu-points::

```
Modemtyp
 D
```

With UP/DOWN you select the following menu-points, with ENTER your selection is used:

D	Germany
USA	USA
Auto	Automatic Selection wich telephone type is used.

1.5.5.4.5 Speaker

With RIGHT or ENTER you enter the following sub-menu where you could select following menu-points::

```
Lautsprecher  
Aus
```

With UP/DOWN you select the following menu-points, with ENTER your selection is used:

Off	Speaker is off
Silent	Speaker is silent
Middle	Speaker is on normal Loudness
Loud	Speaker is at maximum Loudness

1.5.5.4.6 busy identification

With RIGHT or ENTER you enter the following sub-menu where you could select following menu-points::

```
Busy identify  
YES
```

With UP/DOWN you select the following menu-points, with ENTER your selection is used:

YES	busy identify is used
NO	busy identify is NOT used

1.5.5.4.7 ring counter

With RIGHT or ENTER you enter the following sub-menu where you could select following menu-points::

```
Ring counter  
1
```

With UP/DOWN you select the ring counter, the value can be between 0 (no answer on call) to 9.

Handbook Cable & Adapter

1.5.5.4.8 extension

With RIGHT or ENTER you enter the following sub-menu where you could select following menu-points::

```
Extension
YES
```

With UP/DOWN you select the following menu-points, with ENTER your selection is used:

YES	extension is used
NO	extension is NOT used

1.5.5.4.9 outline code

With RIGHT or ENTER you enter the following sub-menu where you could select following menu-points:

```
Outline code
```

With UP/DOWN/RIGHT/LEFT you can select the extension which is preceded before all outgoing calls. With ENTER the selection is used.

1.5.5.5 MPI-BUS

With RIGHT or ENTER you enter the following sub-menu, in which you could choose following sub-menus:

```
MPI-BUS
Baudrate
```

With UP/DOWN you could enter the following sub-menus:

Baudrate	MPI-Baud rate configuration, the baud rate selected here is used, even when another is selected over the PG/PC on connection to PLC.
HSA	select highest station address

local Nr select local stations address for the cable

with LEFT you leave this sub-menu to the menu config. With ENTER you enter the sub-menu.

1.5.5.5.1 Baudrate

With RIGHT or ENTER you enter the following sub-menu:

```
MPI-Baud
187.5k
```

With UP/DOWN you could choose between the following baud rates. With ENTER the baud rate is selected:

12M	6M	3M
1.5M	500k	187.5k
93.75k	45.45k	19.2k

from PC the baudrate which is transfered from PC
 is used

With LEFT (Cancel) or ENTER (Select) you leave the sub-menu to the menu MPI.

1.5.5.5.2 HSA

With RIGHT or ENTER you enter the sub-menu:

```
HSA
31
```

With UP/DOWN you could choose between the following values, with ENTER you select the value:

126	63	31	15
-----	----	----	----

Handbook Cable & Adapter

With LEFT or ENTER you leave this sub-menu to the menu MPI.

1.5.5.5.3 local Nr

With RIGHT or ENTER you enter the following Sub-Menu:

```
lokaleNr  
0A
```

With UP/DOWN the local station number is increased/decreased with one. With RIGTH/LEFT the station number is increased/decreased by 16. The local station number is displayed in hexadecimal.

With ENTER you leave this sub-menu to the menu MPI.

1.5.5.6 *Language*

With RIGHT or ENTER you enter the following sub-menu:

```
Language  
German
```

With UP/DOWN you could select the following languages:

German	Language of menu is German
English	Language of menu is English

With LEFT you leave this Sub-Menu to the Menu config.
With ENTER you choose the language and the sub-menu is leaved to config.

1.5.5.7 *Erase*

The default-configuration is saved to OnBoard-Flash with the correct password.

1.5.6 Hang up

With RIGHT or ENTER you tell the modem to close an active connection and to hang up.

1.5.7 Call

With RIGHT or ENTER you select the following sub-menu:

```
phonebook entry:  
    1
```

UP and DOWN selects the phonebook entry, with ENTER the modem dials the number stored in the entry.

1.6 Technical data

Description	Technical specifications
Dimensions without cables	165 x 90 x 50mm (L x W x H)
Case type	Powder-coated, metallic case (Isolating, connect protective ground to connector on the bottom of the Device with a 6.3mm cable-shoe or power-connector)
Interfaces To the MPI-BUS	RS485(19,2/93,5/187,5/ 500kBaud, 1.5/3/6/12Mbaud)
To the PG/PC	RS232 19,2 / 38,4 / 57,6 / 115,2kBaud MODEM upto 33.6k
To Telephone-line	RJ-11/12
Supply voltage	DC 24V +/- 20% The 24V will be taken out of the connected PLC or external.
Power disurpation	5VA (Typ. I = 200mA at 24V)
Galvanic decoupling	The internal electronic (and RS232) to the bus driver and also to the 24V input are decoupled. The shield from the MPI/PPI side to the RS232 side are connected through

Order Description

MPI-Modem 3m

Order.No. 9352